

OVERVIEW OF BIOGAS TECHNOLOGY IN VIETNAM

By: Do Kim Tuyen

Department of Livestock Production

Email: tuyendokim@yahoo.com



Contents

1. Introduction
2. History of Biogas Technology
3. Some of Biogas Types in Vietnam
4. The Standard of Biogas Technology
5. Conclusions



I. INTRODUCTION

- Since 1990 Vietnam had been known as agriculture products exporter
- Nowadays, Vietnam is the second biggest country in the world for rice exporter with more than 5 mill. tones/year. Also the same second for rubber, coffee and number one black pepper exporter
- So Vietnam is changing economic structure in Agriculture from crops to livestock production



... INTRODUCTION

Livestock population in VN has been increased 8% per year, so livestock waste also increase the environmental pollution.

Animal	2000	2001	2002	2003	2004	2005	2006
1. Pig	20.2	21.8	23.1	24.9	26.1	27.4	26,8
2. Cattle	4.13	3.89	4.06	4.39	4.91	5.54	6,51
<i>Dairy cattle</i>	0.035	0.041	0.055	0.079	0.095	0.104	0,113
3. Buffalo	2.87	2.81	2.81	2.83	2.87	2.92	2,92
4. Poultry	196.2	218.1	233.3	254.1	218.2	219.9	214,5
<i>Duck</i>	51.0	57.9	63.6	69.4	58.9	60	62,6
5. Goat	0.54	0.57	0.62	0.78	1.02	1.31	1,52
6. Horse	0.126	0.113	0.11	0.112	0.113	0.110	0,087

TOTAL ANNUALLY LIVESTOCK WASTE (solid)

*Million
tone*

Animal	Population (Million head)	LS Waste (Million tone)	Untreated (%)
1. Pig	26.8	24.165	80
2. Cattle	6.51	19.530	70
<i>Dairy cattle</i>	0.113	0.339	70
3. Buffalo	2.92	11.680	70
4. Poultry	214.5	2.000	60
<i>Duck</i>	62.6	0.575	90
5. Goat	1.52	0.912	80
6. Horse	0.087	0.250	80
Total		59.010	

II. HISTORY OF BIOGAS TECHNOLOGY IN VIETNAM

1. PERIOD 1964 – 1975

Northern Vietnam

- 1964, The Ministry of Industry started with the **first “Methane power station” of Vietnam in Bac Thai province.**
 - 1965-1975, Hanoi, Ha Nam Ninh and Hai Hung provinces also own some biogas plants,
 - However, these plants stopped functioning shortly due to lack of technology and management experiences.
- 

Southern Vietnam:

- **The Department of Animal Husbandry conducted research on collecting methane gas from animal manure, but the results could not put into practice,**
- **From late of 1960s to the 1975 the methane gas production and biogas technology in Vietnam was almost forgotten**



2. PERIOD 1976 – 1980

- In 1976, the National research on “*fermentation for methane gas production*” by the Vietnam Institute of Energy.
- **Research work focused on the design, development and testing of suitable biogas plant,**
- **But these systems, could not function for a long time, due to lack of technology cooperation and Financial support.**



3. PERIOD 1981 – 1990

- **The National Research Program on New Energy Sources by the Institute of Electricity Science and Technology,**
- **Participation: institutes, research centers, colleges collaborating with army units, individuals...**
- **Financial and Technology Supported by: Biochemistry and Microbiology Soviet Union, OXFAM UK, UNICEF, French speaking countries and SIDA of Sweden...**



....PERIOD 1981 – 1990

- **By 1990, about 2,000 biogas units had build in Vietnam with family-scale and the size from 3m³ – 10m³**
 - **The first national workshop on biogas was organized within the framework of the National Program on New Energy Sources.**
 - **This was a leap forward to the research and development of methane gas & biogas technology in Vietnam.**
- 

4. THE PERIOD: FROM 1991 up to now

- From 1991 to 2001, biogas technology has been rapidly developed with strong assistances of the Government and International organizations.
- In 2002, the standards on small-scale biogas systems were issued by MARD.
- In 2003, the Netherland-VN project on “ *Support the biogas program for the livestock sector in some provinces of Vietnam*”.



...THE PERIOD: FROM 1991 up to now

- **2005, livestock waste management project from GEF and FAO (Thailand, Guang Dong-China and Vietnam).**
- **2006, the Globe Energy Award for Vietnam**
- **2007, the number of biogas units over the whole country is : 73.000 units,**
- **The Plan and target for 2010 is 140.000 units including the big plants**



III. SOME OF BIOGAS TYPES IN VIETNAM

1. Floating gas holder unit

Steel reinforced gas holder facing down to a water-collecting slot around the digester neck.

Can be developed to the large size biogas plant,

High cost, short lifetime.

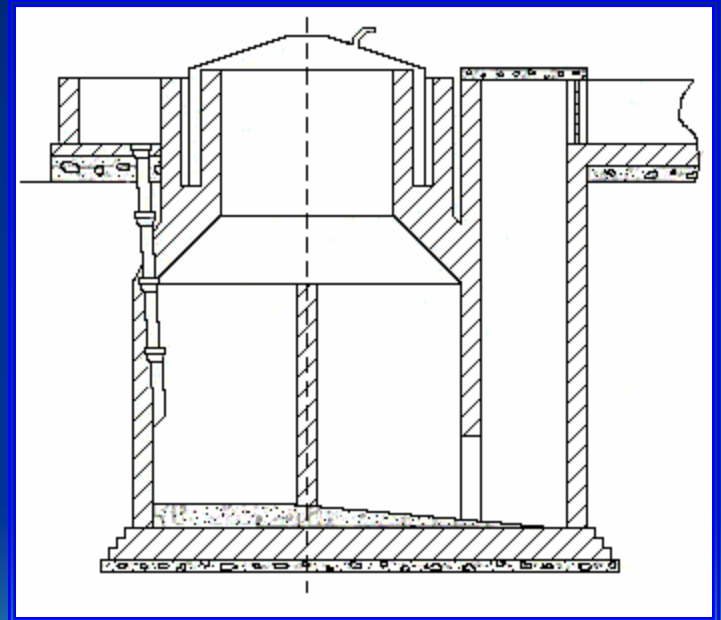

2. Biogas with nylon bag

Nylon bag with a separated gas accumulation bag

The National Institute of Animal Husbandry and The Agriculture and Forestry University of HCMC and its satellites are developing,

Many organizations stop developing this type of biogas plant due to so many disadvantages

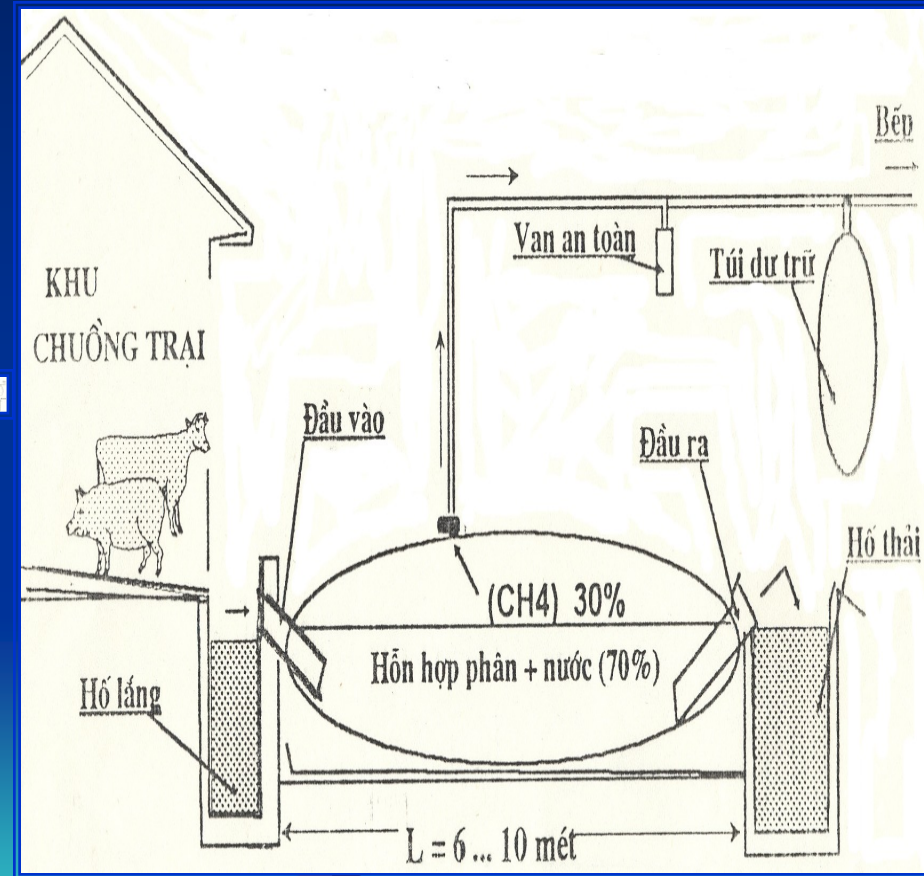

3. The fixed dome biogas plant

The parallelepiped digester: RDAC type (new)

+The cylinder digester had been changed into the parallelepiped form, with a composite hemisphere cover.

+This form is easier to be built, with gas tighten ,

Disadvantages:

- High cost,
- Inappropriate technology parameters

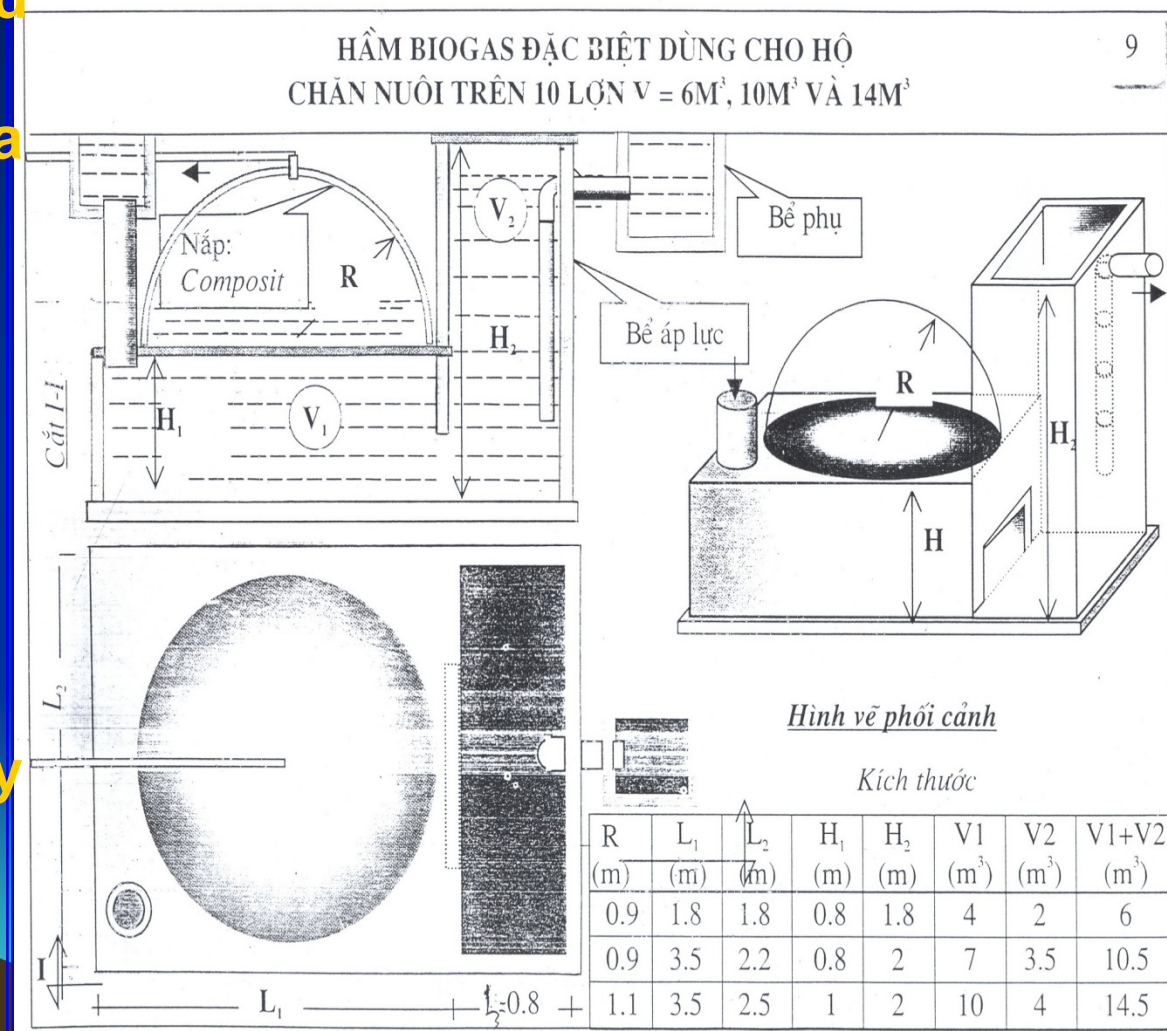

The Energy Institute type LN.6

+ This is the only type approved by the National Appraisal Council

+ This type has been continuously improved during the last ten years.

+ This type is selected as sample model for “The Standard on Small Biogas Plant”

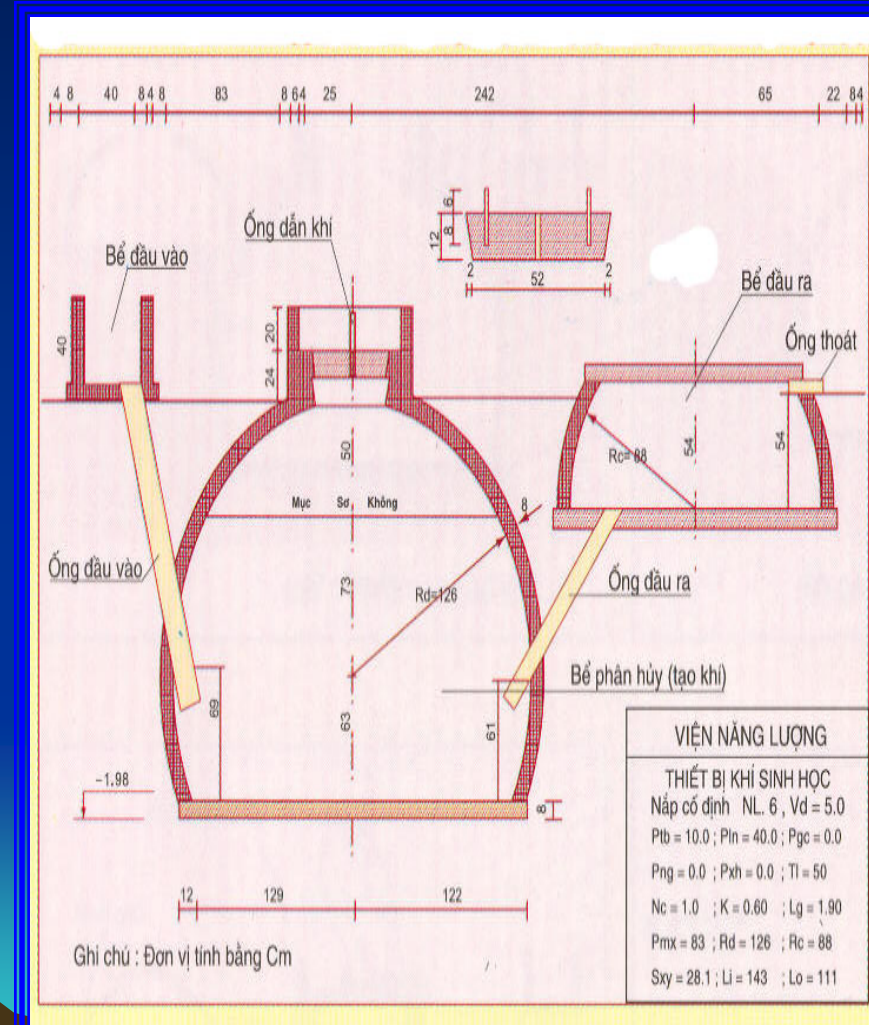

Advantages of NL-6 model

- **Low cost,**
- **Using locally available materials and human resources,**
- **Easy for construction,**
- **Suitable to diversified climatic conditions and inputs for digesters,**
- **Has long lifetime.**



IV. THE STANDARD OF BIOGAS technology in Vietnam

**The Standard No 10 TCN 499-2002 was issued by
Ministry of Agriculture & Rural Development of
VN in 2002**

- **The aims:**
 - **Standardization of biogas production and utilization,**
 - **Protection of the biogas users' right**
 - **Promotion of the sustainable biogas technology development.**
 - **Environmental protection**



1. The consists of the standard

- **1. General technology requirements,**
- 2. Biogas construction,**
- 3. Biogas distribution and use,**
- 4. Monitoring and evaluation,**
- 5. Operation and maintenance,**
- 6. Safety requirements,**
- 7. List of basic parameters and specifications**
- 8. The biogas unit designs**



2. House hold- Model: KT1

Fixed-dome
with deep
spherical
shape biogas
plant.

Use for good
earthground
with level III
and VI.

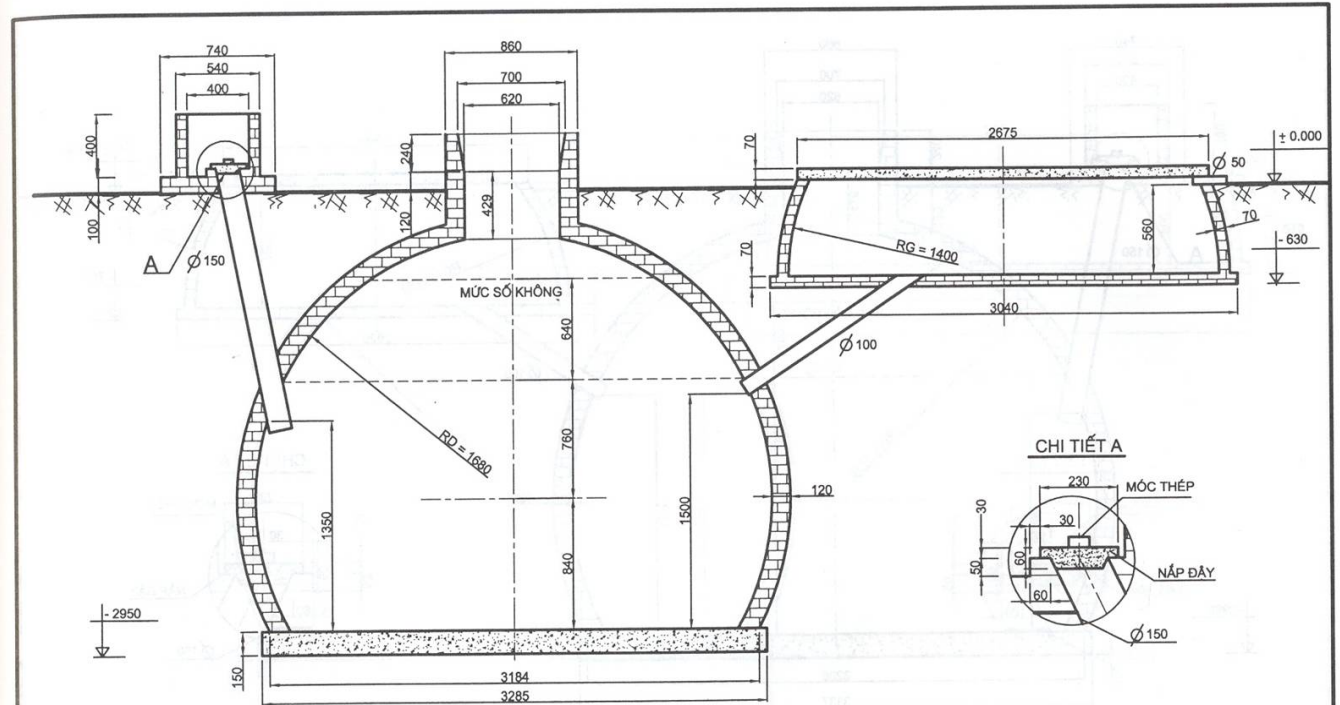

GHI CHÚ:

- VỊ TRÍ TƯƠNG ĐỐI GIỮA BẾ ĐIỀU ÁP, BẾ PHÂN HUỖ, BẾ NẠP TÙY THEO MẶT BẰNG.
- CHI TIẾT CỔ BẾ PHÂN HUỖ, NẮP BẾ ĐIỀU ÁP XEM BẢN VẼ CHI TIẾT KÈM THEO.
- BẾ TÔNG ĐÁY MÁC 200.
- GẠCH XÂY MÁC 75, VỮA XI MĂNG CÁT MÁC 75.
- TRÁT MẶT TRONG THEO QUI TRÌNH 5 LỚP.
- HAO PHÍ VẬT LIỆU:

+) XI MĂNG: 1510 KG	+) SỎI: 1.4 M3
+) GẠCH: 3080 VIÊN	+) THÉP (D6): 33 KG
+) CÁT: 3.2 M3	

CỤC NÔNG NGHIỆP - TỔ CHỨC PHÁT TRIỂN HÀ LAN SNN
DỰ ÁN HỖ TRỢ CHƯƠNG TRÌNH KHÍ SINH HỌC
CHO NGÀNH CHĂN NUÔI MỘT SỐ TỈNH VIỆT NAM

THIẾT BỊ KHÍ SINH HỌC NẮP CỐ ĐỊNH KIỂU KT.1
CỖ THIẾT BỊ : V = 16.51 M3; VD = 13.0M3; VG = 3.25 M3

Model KT2

Fixed-dome
with shallow
spherical shape.

Use for high
ground water
areas.

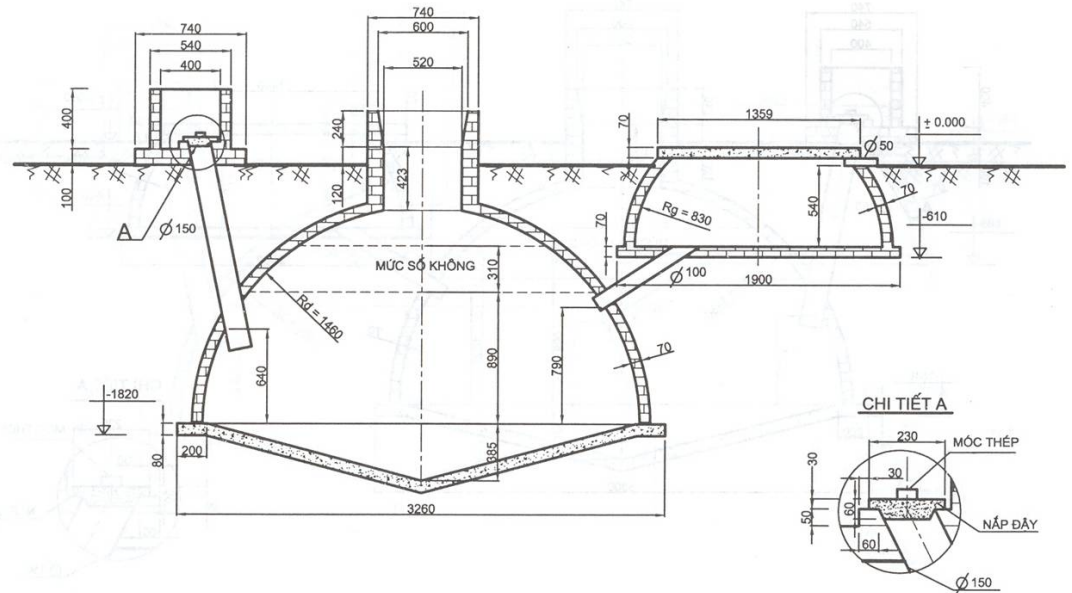

GHI CHÚ:

- VỊ TRÍ TƯƠNG ĐỐI GIỮA BỂ ĐIỀU ÁP, BỂ PHÂN HỦY, BỂ NÁP TÙY THEO MẶT BẰNG.
- CHI TIẾT CỐ BỂ PHÂN HỦY, NÁP BỂ ĐIỀU ÁP XEM BẢN VẼ CHI TIẾT KÈM THEO.
- BÊ TÔNG ĐÁY MẮC 200.
- GẠCH XÂY MẮC 75, VỮA XI MĂNG CÁT MẮC 75.
- TRÁT MẶT TRONG THEO QUI TRÌNH 5 LỚP.
- HAO PHÍ VẬT LIỆU:

+) XI MĂNG: 630 KG	+) SỎI: 0.7 M3
+) GẠCH: 1040 VIÊN	+) THÉP (D6) : 8 KG
+) CÁT: 1.3 M3	

CỤC NÔNG NGHIỆP - TỔ CHỨC PHÁT TRIỂN HÀ LAN SNV
DỰ ÁN HỖ TRỢ CHƯƠNG TRÌNH KHÍ SINH HỌC
CHO NGÀNH CHĂN NUÔI MỘT SỐ TỈNH VIỆT NAM

THIẾT BỊ KHÍ SINH HỌC NÁP CỐ ĐỊNH KIỂU KT.2
CỖ THIẾT BỊ : V = 7.14 M3; VD = 6.0M3; VG= 1.0 M3

Model KT-2B

Fixed-dome
with deep
spherical
shape biogas
plant,

Use for hard
earth areas

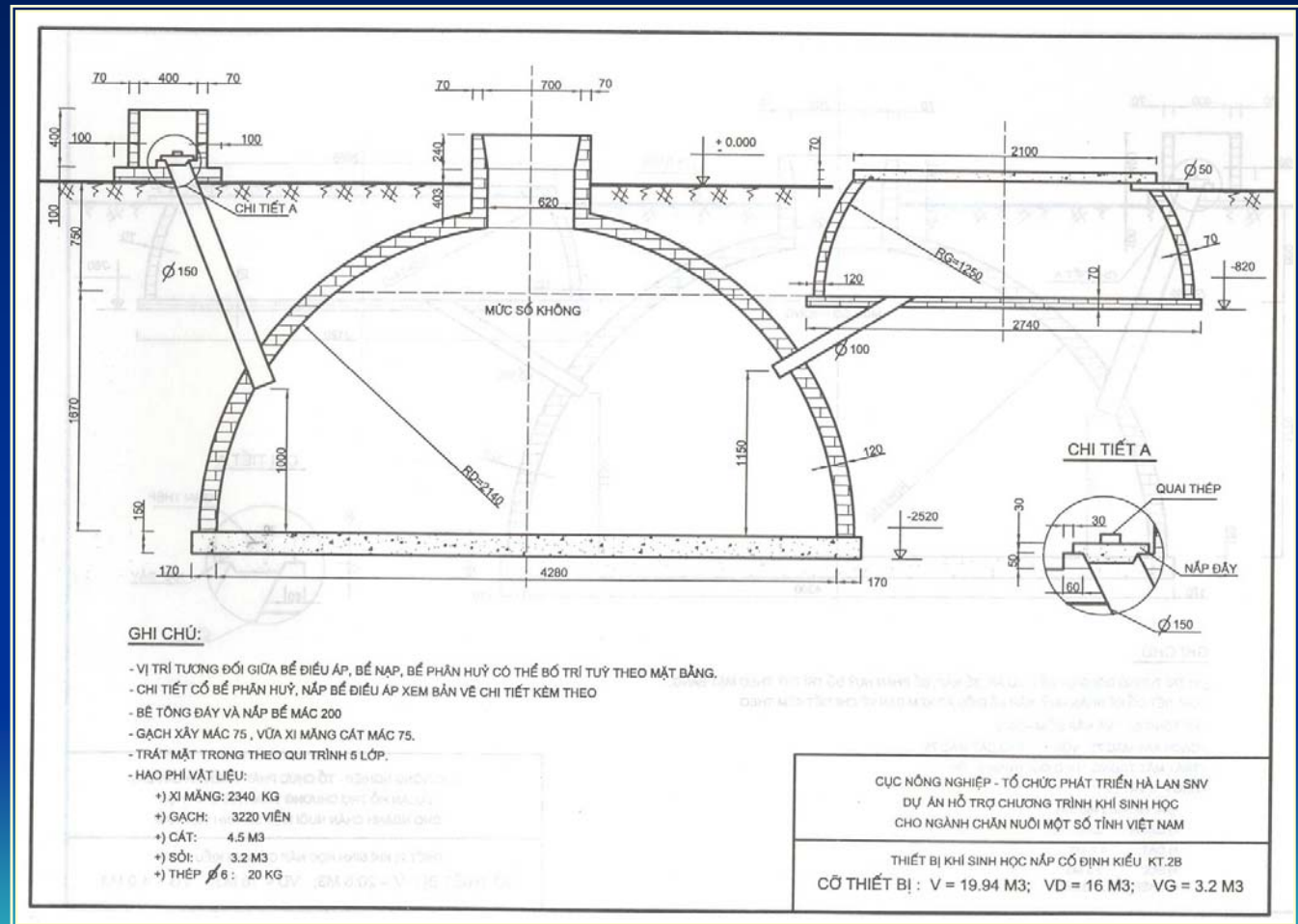

3. Large sized biogas plant

- For the large-sized animal husbandry farms (Swine and Dairy)
- Biogas technology is suitable solution for reduce environmental pollution.



4. Utilization of biogas plants

- **1. *Gas utilization:***
- Biogas burners and lamps are designed and manufactured with high quality and acceptable costs.
- Research work on using biogas as fuel for generator has been successful.
- However, not been widely applied, since most of biogas are small-sized, the amount of gas produced is insufficient for gas generator.



2. Utilization of bio fertilizer

- **Currently, the farmers often use slurry as fertilizers for crops: maize, cabbage, rice... the pests and diseases on these crops are decreased, thus reducing the amount of chemical fertilizers.**
- **Optimal utilization of liquid bio slurry from biogas plants is one of the main activities under the framework of the current Vietnam-Netherlands biogas project.**



V. CONCLUSION

1. **Biogas technology is developed in conjunction with sustainable development of agricultural economics.**
2. **National standard technology specifications is very important for a successful for extension of biogas program,**
3. **Biogas production in large scale and commercial system is necessary for VN in the coming years**
4. **Development and application of Methane technology should be under the National and International cooperation program.**

Look forward for your cooperation!

