



**Technical
Aspects and
Operating
Requirements
for Digesters
Utilizing
co-mingled
Waste and
Centralized
Operation in
Cold Climates**

Heinz-Peter Mang
Beijing Institute for Energy and
Environmental Protection





农业部
Ministry of Agriculture

农业部科技发展中心
Center for Science and Technology Development

农业部能源环保技术开发中心
Center for Energy and Environmental Protection

农业部沼气科学研究所
Biogas Research Institute

科技教育司
Department of Science, Education
and Rural Environment

可再生能源处
Division of Renewable Energy

中国沼气学会
China Biogas Society

中国农村能源行业协会
China Rural Energy Association

农业部微水电设备质量
监督检验测试中心
Test Center for Micro-hydro Power Equipment Quality

农业部节能产品及设备质量
监督检验测试中心
Test Center for Energy-saving Product/Equipment Quality

农业部沼气产品及设备质量
监督检验中心
Test Center for Biogas Product/Equipment Quality

省级农村能源办公室
Rural Energy Office at Provincial Level

县级农村能源办公室
Rural Energy Office at County Level

乡镇级农村能源技术推广站
Rural Energy Station at Township Level

Organizational chart of
MOA Renewable
energy management
system

农业部的可再生能源
管理体系

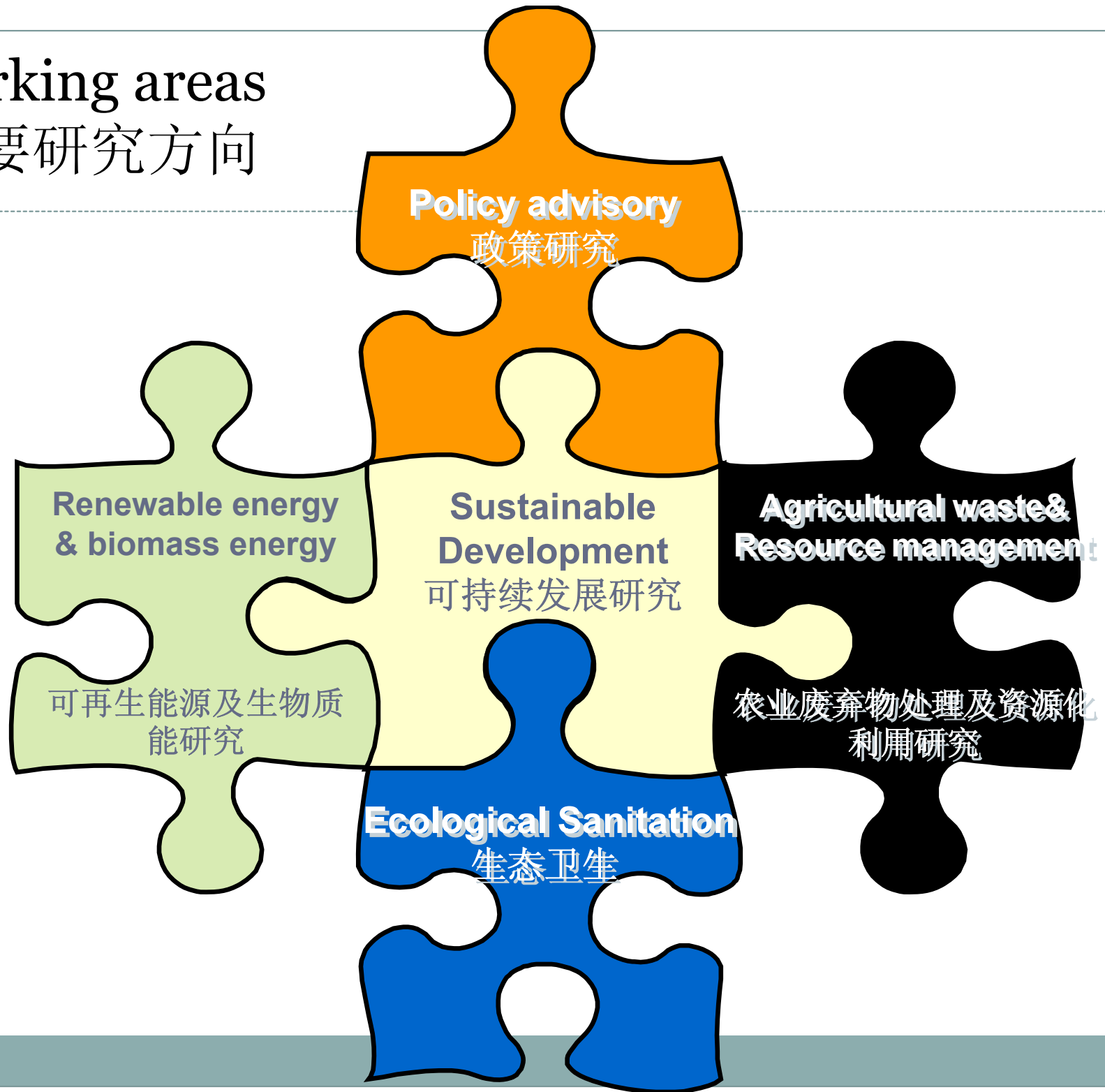

working areas
主要研究方向





Institute of Energy and Environmental Protection



- Embedded in two structures: as IEEP in the Chinese Academy of Agricultural Engineering (CAAE) , and as Centre for Energy and Environmental Protection Technology Development (CEEPTD)  belonging to the Ministry of Agriculture
- Co-Owner of  Hongyuan Energy and Environment Co. Ltd. – for Greenhouse Gas Emissions Reduction in Chinese Township and Village Enterprises
- CDM - business plan development expertise
- Carbon emission reduction project team with special expertise for methane emission reduction and energy efficiency
- Public-Private Partnership with Chinese and European companies

中心职能 CEEP / IEEP is engaged in:



- 农村能源与农业生态环境宏观政策研究；
Macro-policy studies on rural energy and rural environmental protection .
- 农村能源与农业环境保护重大项目技术指导和管理；
Develop and administrate key projects in rural energy and rural environmental protection.
- 农业废弃物处理及资源化利用技术研究及推广；
Research and promote technologies of agricultural waste treatment and sustainable resources utilization.
- 农业废弃物处理及资源化利用工程设计与建设；
Design and construct projects for agricultural waste treatment and sustainable resource utilization.
- 农村能源和农业环境保护国际交流与合作、人员培训；
International cooperation, information exchange and staff training.
- 农村能源职业技能鉴定站日常管理。
Administration of a Vocational Training Centre for Rural Energy Skills

German Society for Sustainable Biogas and Bioenergy Utilisation, **GERBIO** ...



- ... is a registered German non-profit association
- ... was founded in 2001
- ... **promotes sustainable closed-loop approaches as well as sustainable crop rotation systems**
- ... opposes mono-cultures and GMO crops
- ... supports practitioners with its knowledge and its world-wide network

GERBIO's focus points



BIOGAS



Plant and vegetable oil



Wood gas



Manure management



Ecological sanitation

GERBIO has the knowledge



- long-term experience of its board members (since 1980s)
- knowledge transfer (seminars, study tours and trainings)
- members work with/are farmers and constructors (plant operators, manufacturers)
- active exchange of knowledge within a world-wide network
- extensive international library about biogas, sanitation and agricultural engineering



Content



- 1) Co-mingled waste**
- 2) Technical aspects**
- 3) Operating requirements**
- 4) Centralized operation**
- 5) Cold climates**

Electricity output with co-fermentates



Electricity output

(in kWh per M.T.)

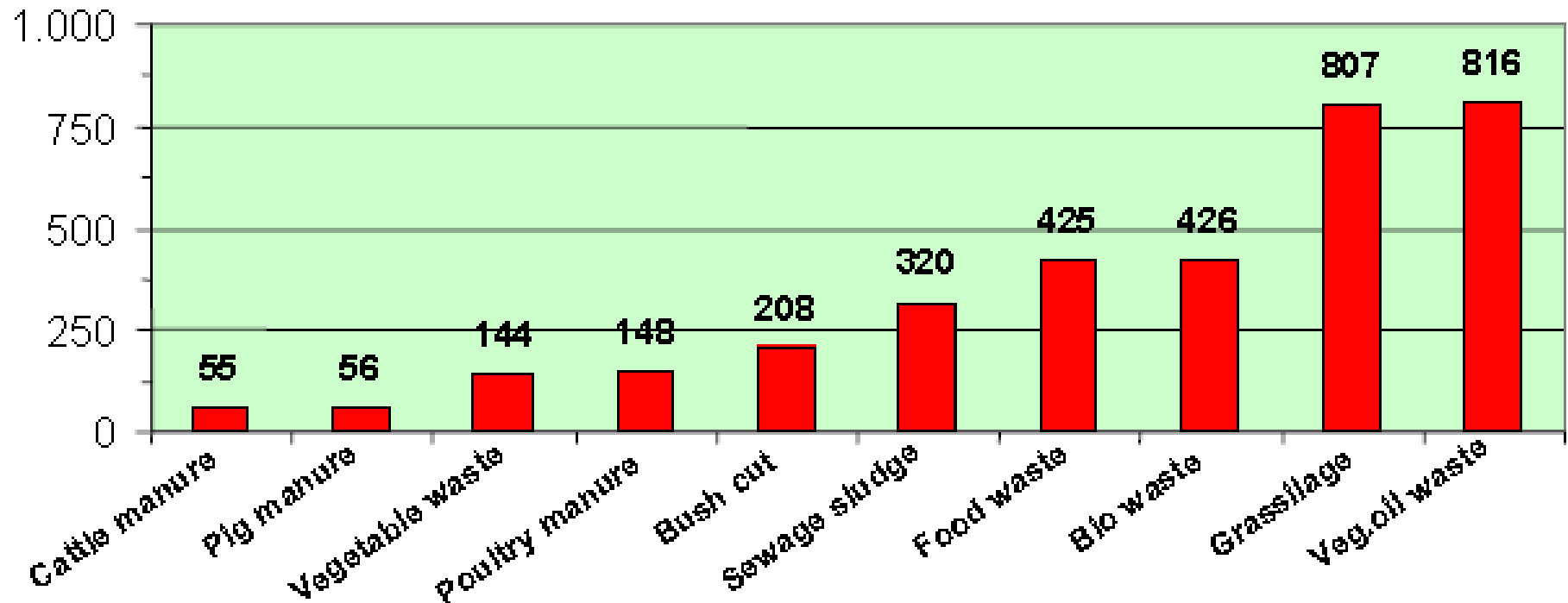

Specific yield of biogas (1/2)



Substrat	TS		oTS		Biogas			
	%		%		m ³ CH ₄ /kg TS		m ³ CH ₄ /kg/oTS	
	between	to	between	to	between	to	between	to
Raw glycerine (RME man.)	>98		90	93	0,62	0,67	0,69	0,72
Potato tops	25		79		0,40	0,47	0,50	0,60
Beet (turnip) tops	15	18	78	80	0,19	0,40	0,24	0,50
Diverse cereals	85	90	85	89	0,26	0,53	0,30	0,60
Clover	20		80		0,32	0,40	0,40	0,50
Apple slop	2	15	90	95	0,30		0,33	
Apple pomace	25		86					
Spent grains from beer	20	22	87	90	0,22	0,63	0,25	0,70
Spent hops (dried)	97	97,5	90		0,45	0,50	0,50	0,55
Filtration silica gel (beer)	30		6,3		0,02	0,02	0,30	0,35
Vegetable waste	5	25	76	90	0,18		0,24	0,40
Old bread	90		96	98	0,67	0,74	0,70	0,75
Coco bean shells	95		91					
Potato slop	12	15	90		0,22	0,50	0,24	0,55
Cereal slop	6	15	87	90	0,52		0,60	
Foliage			82		0,33		0,40	
Melasse	80		95		0,29		0,30	
Whey	4	95	80	92			0,48	0,60
Fruit pomace	45		93		0,25	0,48	0,27	0,52
Oil seed residue (pressed)	92		97		0,56	0,60	0,58	0,62

Specific yield of biogas (2/2)



Substrat	TS		oTS		Biogas			
	%		%		m ³ CH ₄ /kg TS		m ³ CH ₄ /kg/oTS	
	between	to	between	to	between	to	between	to
Rape extraction residue	88		93		0,24	0,59	0,26	0,63
Grape pomace	40	50	80	95				
Casto extraction residue	90		81					
Food waste (from large kitchens)	9	40	55	98	0,20	0,64	0,36	0,65
Vinasse	63		53					
Organic waste (domestic)	30	75	30	90	0,05	0,54	0,18	0,60
Park and garden waste (fresh)	12	42	87	97	0,18	0,49	0,21	0,50
Clippings (sedge)	37		93		0,47		0,50	
Blood meal	90		80					
Flotation sludge	5	24	93	98	0,56	0,78	0,60	0,80
Stomach content (pigs)	12	15	80	84	0,16	0,25	0,20	0,30
Rumen contents (untreated)	11	19	80	88	0,21	0,35	0,26	0,40
Rumen contents (pressed)	20	45	90		0,54	0,63	0,60	0,70
Slaughter house waste							0,20	0,43
Fisch processing waste							0,30	
Animal cadaver meal	8	25	90		0,45	0,72	0,50	0,80
Separator fat (gelatine prod.)	25		92					
Fat (from fat separators)	2	70	70	100	0,29	0,70	0,42	1,00
Market waste	5	25	76	90			0,30	0,40
Residual waste	55	57	46	78	0,06	0,30	0,13	0,39

Advantages of anaerobic digestion



Very wet waste can be digested – this is not possible by composting

- Slaughter house waste
- Fat – glycerine – flotation fat and grease
- Organically loaded waste water
- Liquid organic waste
- Faecal sludge

The bottleneck of anaerobic digestion



Methane Bacteria

They are

- Sensitive on low temperature $< 37^{\circ}\text{C}$
- Sensitive on temperature change
- Sensitive on low pH value $< 7,0$
- Sensitive on high organic load $> 3,0 \text{ kg/m}^3/\text{day}$

Growing of anaerobic bacteria

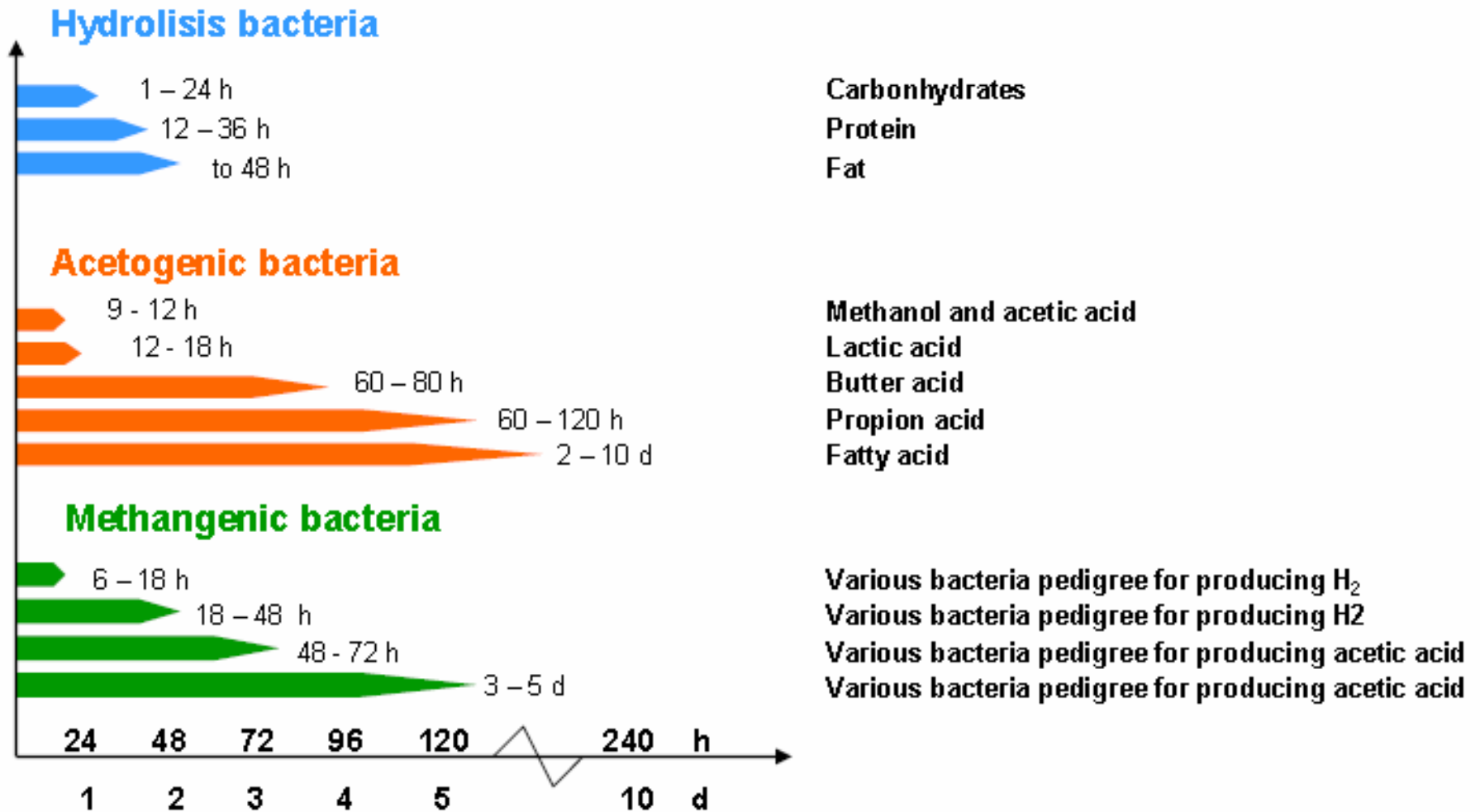

Source: Walter Danner & Alexander Varghese, UNIDO consultants

Closing the nutrient loop

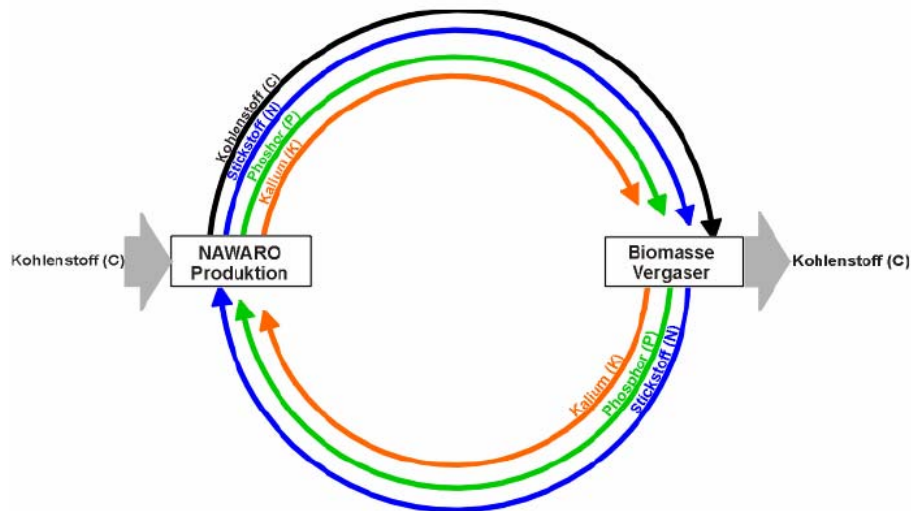

- Nutrient are still in the effluent as fertilizer, mainly the carbon is used for the biogas production.
- Clean fertilizer due to appropriate sorting technology possible.
- Source separated collection produces fertilizer without toxic elements.
- Complete hygienisation possible.

Optimized agricultural nutrient cycle

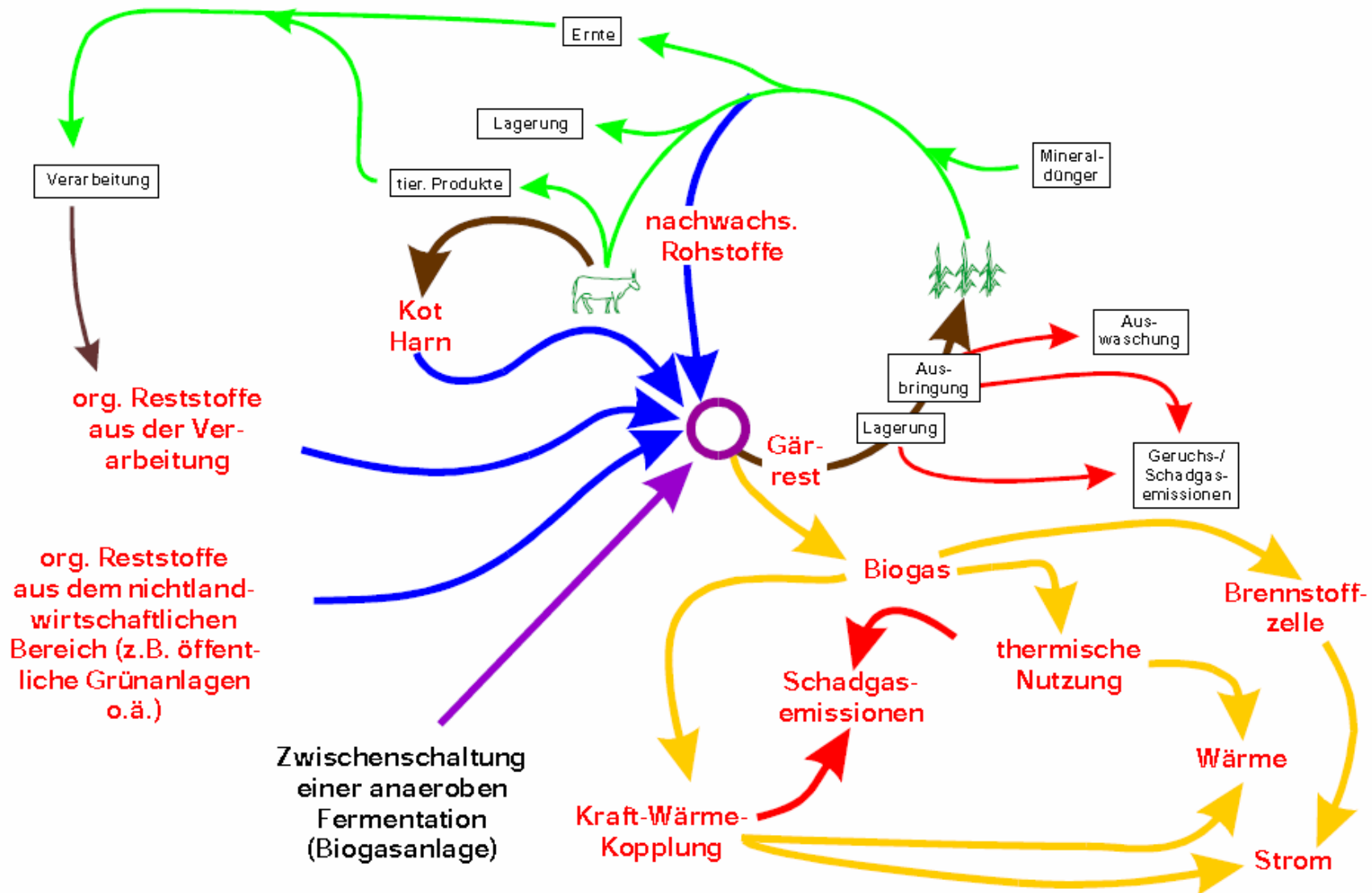



Process chain for the digestion of biowaste

Biogas

Reception of biowastes
=> closed chamber with
odour treatment

Preparation
=>Chopping and
sorting of disturbing materials

**Fermentation
with post treatment**

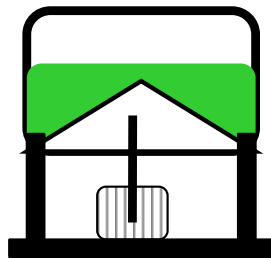
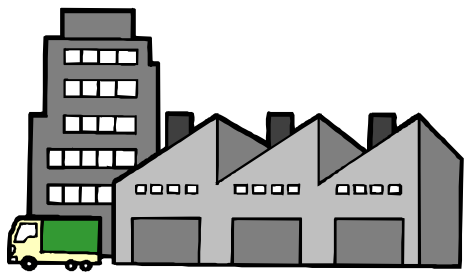

Pulper

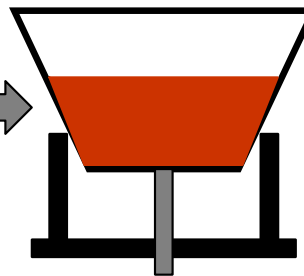

hygienising, separation

compost

(post composting)

liquid fertilizer



Up to 5 step preparation of co-mingled waste

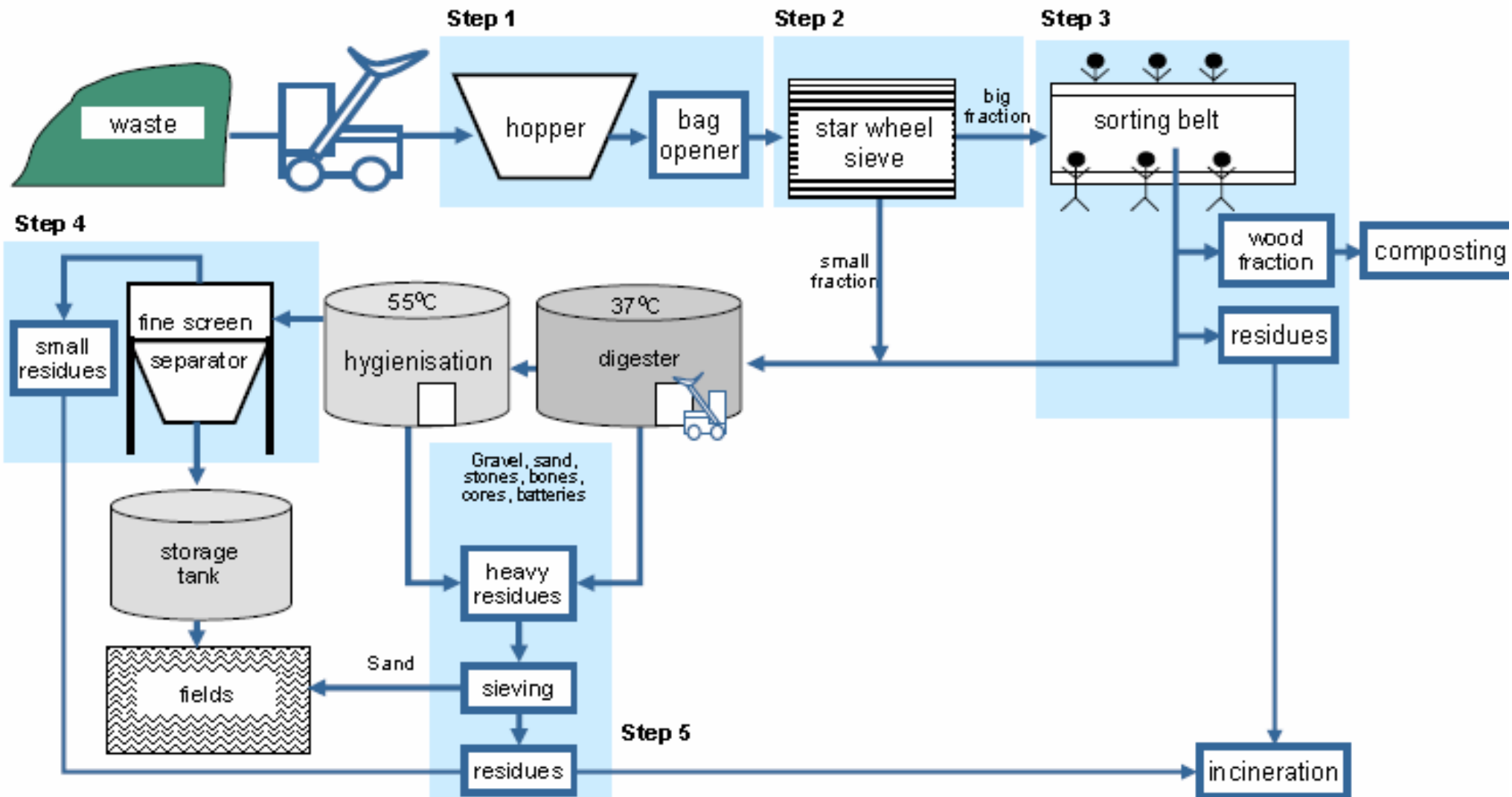

General design criteria



- Heat and power utilization
- Fertilizer use – nutrient balances
- Effluent preparation
- Type of feedstock and availability
- Affordable investment – additional income generated
- Maintenance – costs, skills, spare parts availability
- Suitable to the climate – stable process
- Available and manageable construction material
- Transportation during construction and for feedstock
- Labour costs
- Size of potential market for fertilizer and technology

Feed-in technology for Energy Crops

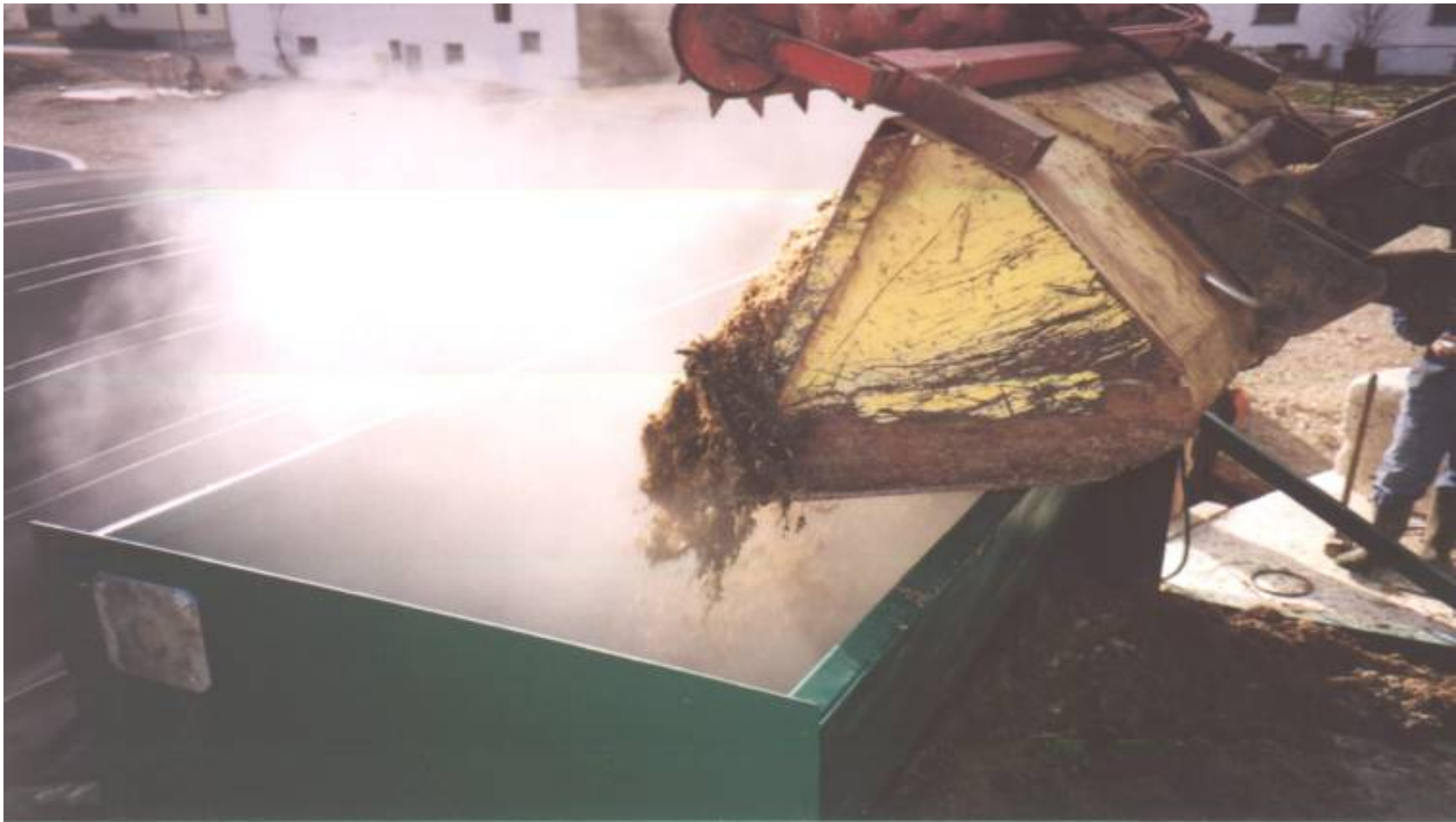

Feed- in of solid material





**solid
feed-in gear**





Liquid Biomass Feeding

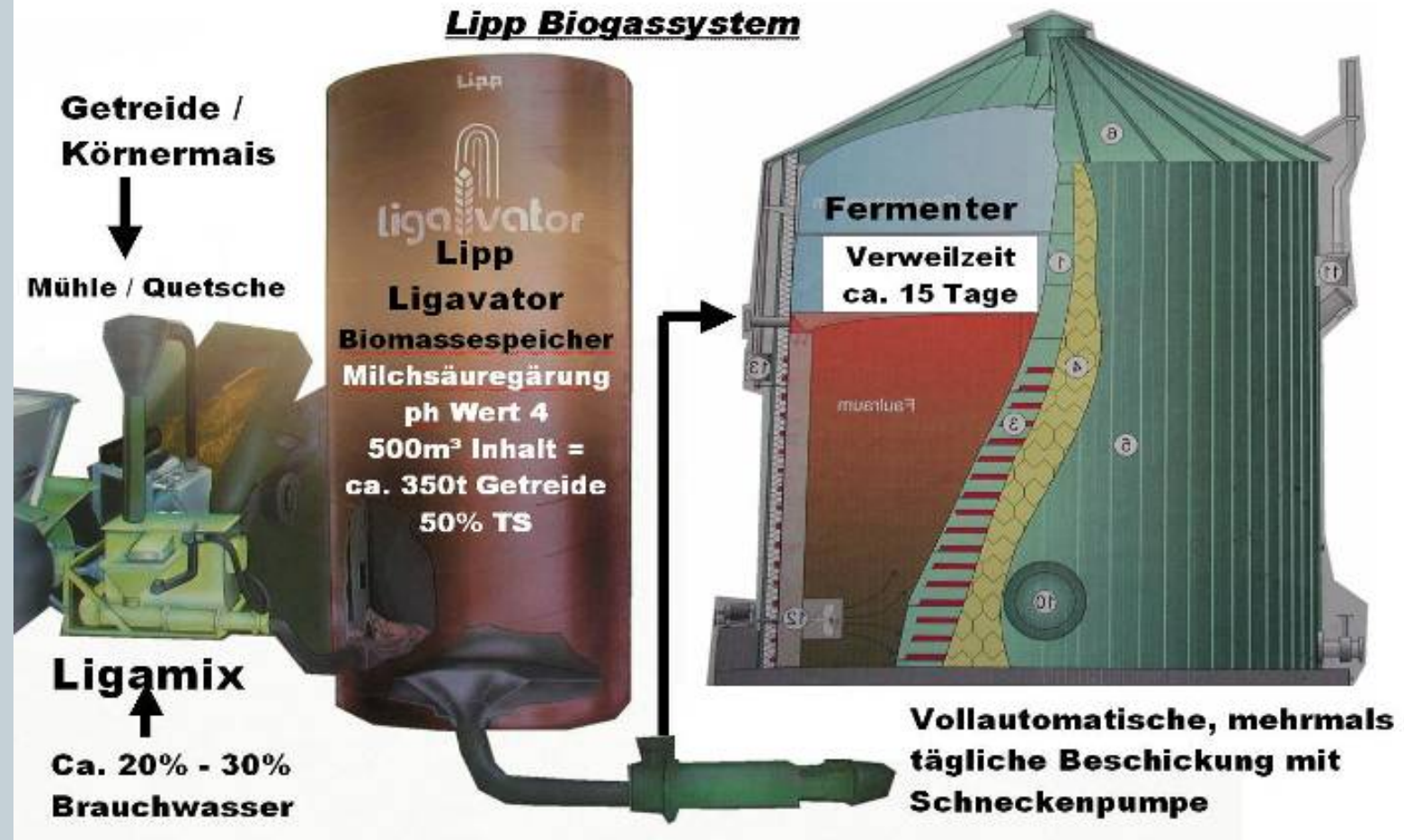



Different feed-in systems

Wash in channel
with KG pipe

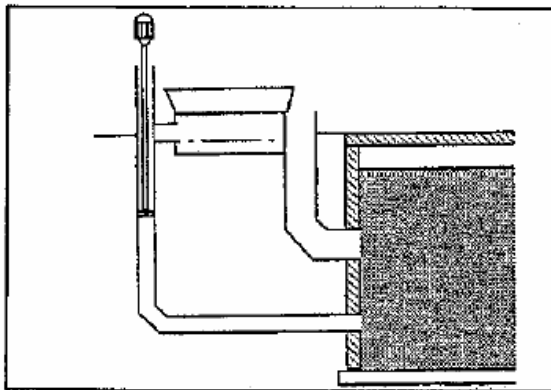

Wash in shaft
(Hochreiter)

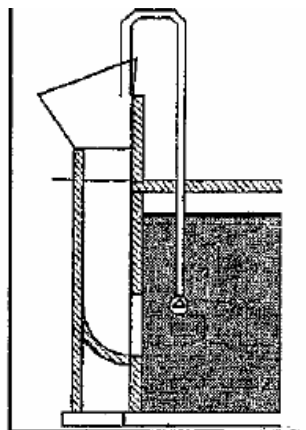

Throw in shaft
(ceiling)

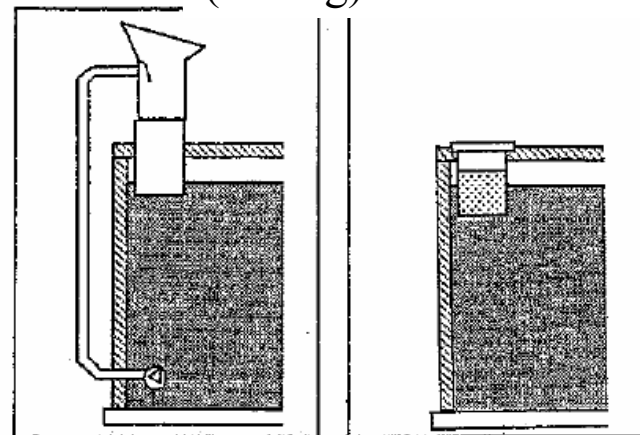

Throw in shaft
(lateral wall)

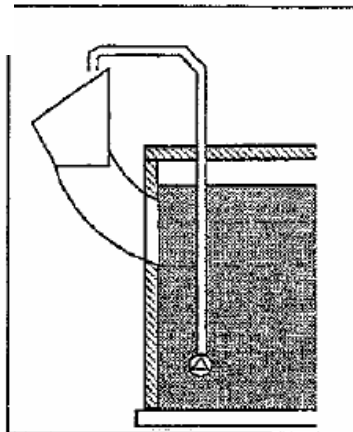
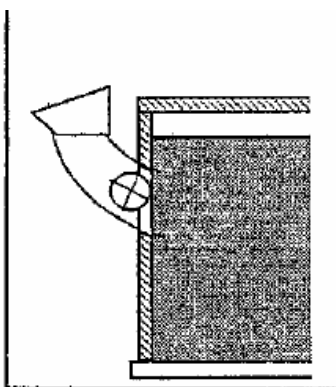

Feed in gear
horizontal

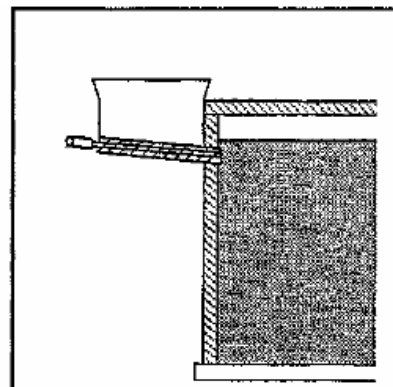

vertical

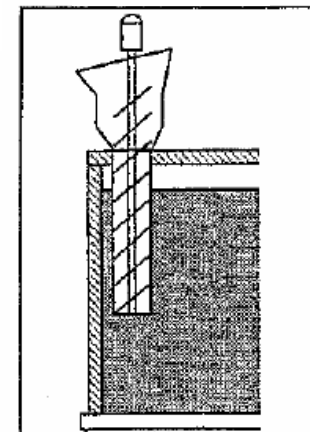

- input

Mixing



- Homogenization
- Stimulate gas exit
- Avoid sink material
- Avoid floating material, crushing of crust



Mixing





Mixing devices

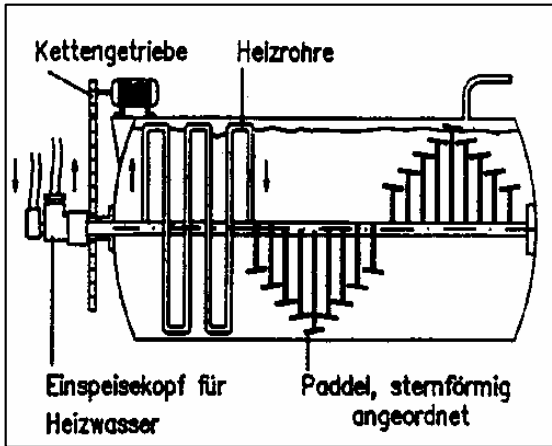

Mechanical paddle mixing device with heating pipes

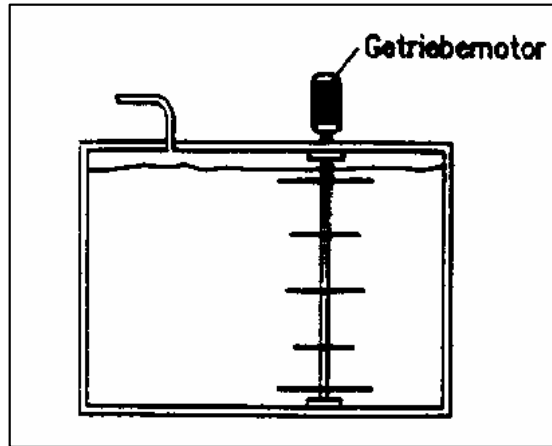

Mechanical mixing device (Grindelrührwerk) excentrically placed

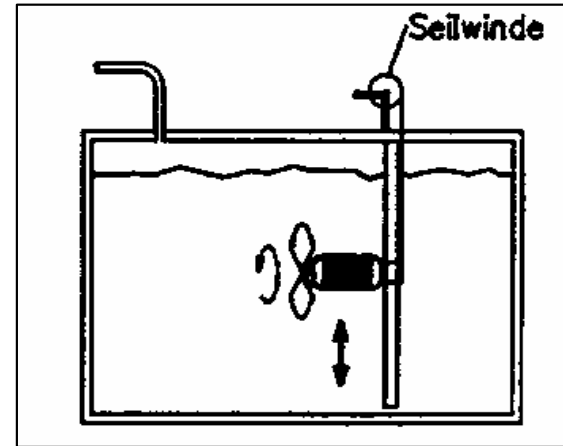

Immersion engine propeller mixing device -adjustable

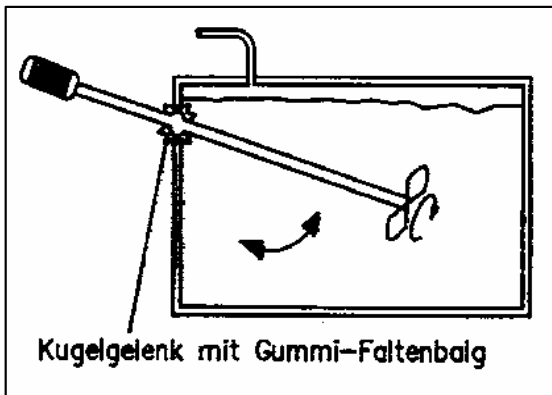

Rod mixing device, swivelling

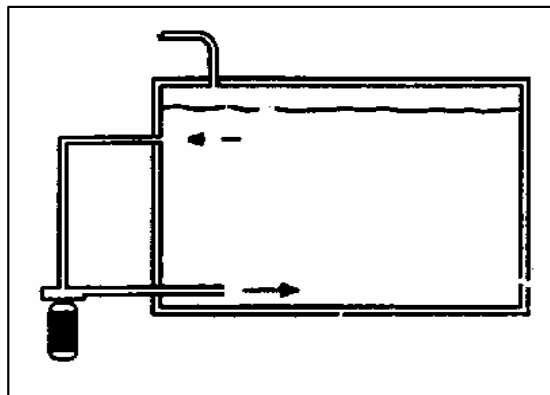

Hydraulic circulation

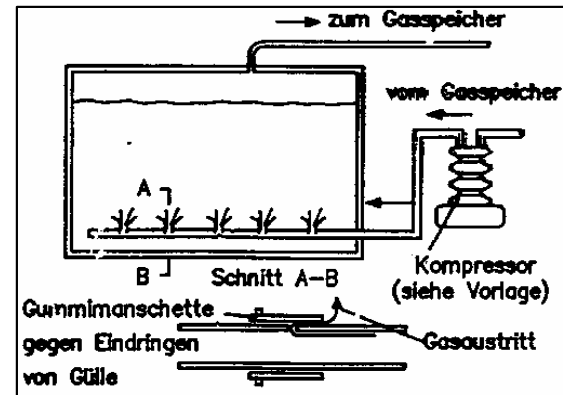

Pneumatical injection of

- Mixing

Sorting and preparation for centralized operation



Receiving



Sorting



Digestion



Electricity Production



Biogas Production

Insolation



- Minimization of process energy need
- Avoid temperature losses
- Avoid temperature differences

Materials:

Floor and roof
(concrete roof): Styropor

Wall and roof (plastic cover):
Polystyrol



Insolation



Heating

Warming the digesting substrate at optimal temperature.

Compensation of the lost temperature.



Heating



- Risk- and Insurance Management

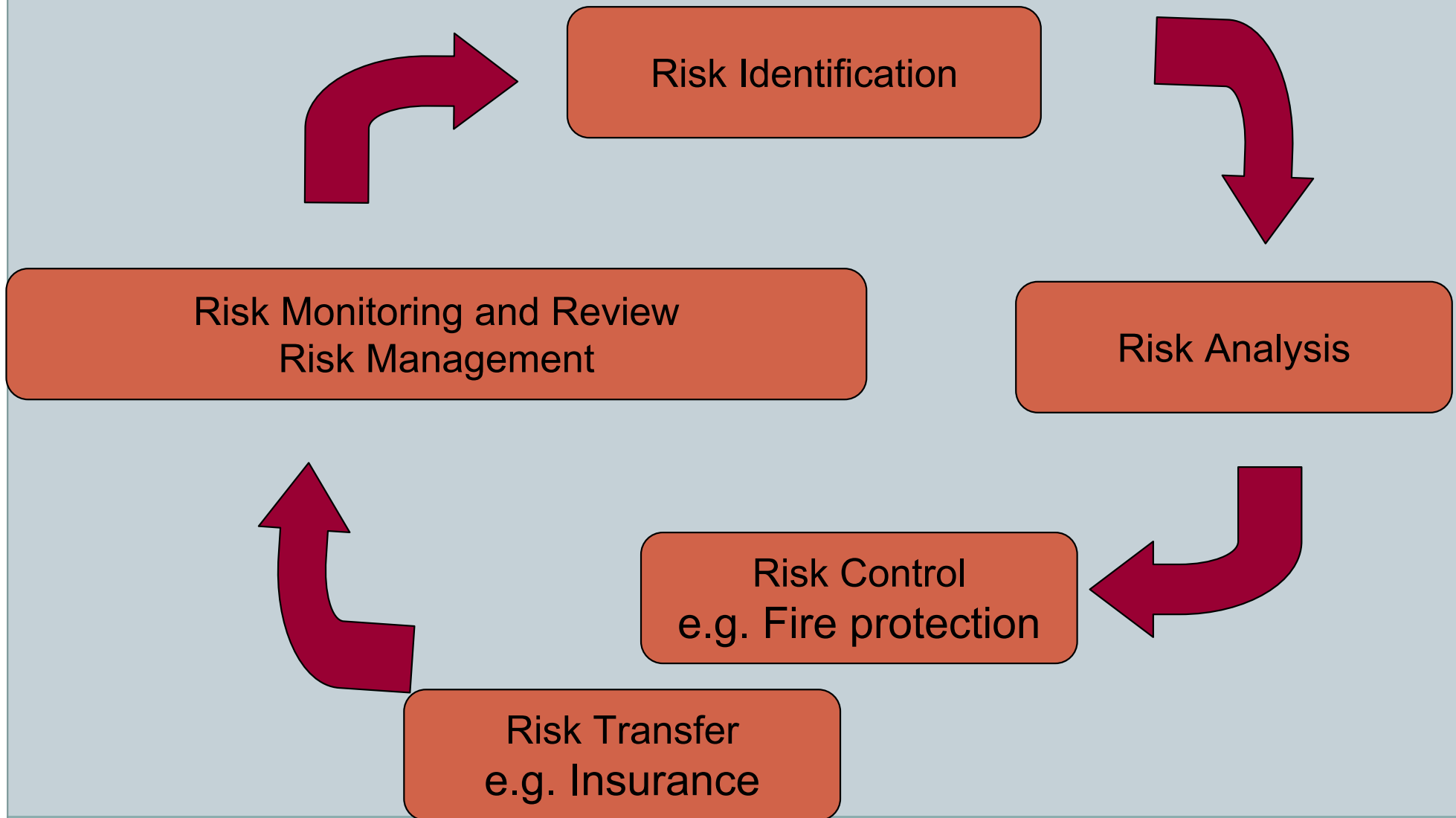

All Risk Insurance for biogas plants

- No separation in Fire and Machinery Breakdown



- What is insured?

All components of the plant required for the operations and for maintaining these operations

- Machines, Installations, Buildings, Pipe Works

– Fermenter Biology

- All Risk Insurance

- Insured is the unforeseen damage or loss while not being excluded by a specific named peril

Not Insured Perils



- ✗ Caused deliberately by or due to gross negligence of the insured or the responsible manager
- ✗ For which supplier or the repair workshop are responsible or liable (supplier's guarantee)
- ✗ Which are a direct consequence of permanent influence from operation (e.g. wear and tear)
- ✗ War, Riots
- ✗ Nuclear Energy

Insured Perils

- Examples (no completed list)



- ✓ Fire, Lightning, Explosion
- ✓ Machinery Breakdown (e.g. motor loss), failure in material, construction or design
- ✓ Natural hazards
 - Storm, Hail, Flood
 - Earthquake, Land subsidence
 - Snow pressure, Avalanche
- ✓ Errors in Operating, Faulty Operation
 - Recourse against employees only if damage is caused by deliberate action
 - Wear/Corrosion and secondary damage
- ✓ It is possible to extend cover for Fermenter biology if it is damaged from the outside (e.g. poisoned)

Indemnification



- ✓ Repair work, replacement of parts
(incl. additional cost for overtime, work on Sundays and public holidays, night work, express delivery)

- ✓ Loss in Revenues for Electricity Production
according to EEG (Erneuerbare-Energien-Gesetz)
(Renewable Energy Law)

- ✓ Loss in revenues for
 - Acceptance of co-ferments
 - Sale of heat
 - Sale of biogas
 - etc. (according to declaration)

Damages at different plant components

- Payment of Compensation relating to plant components

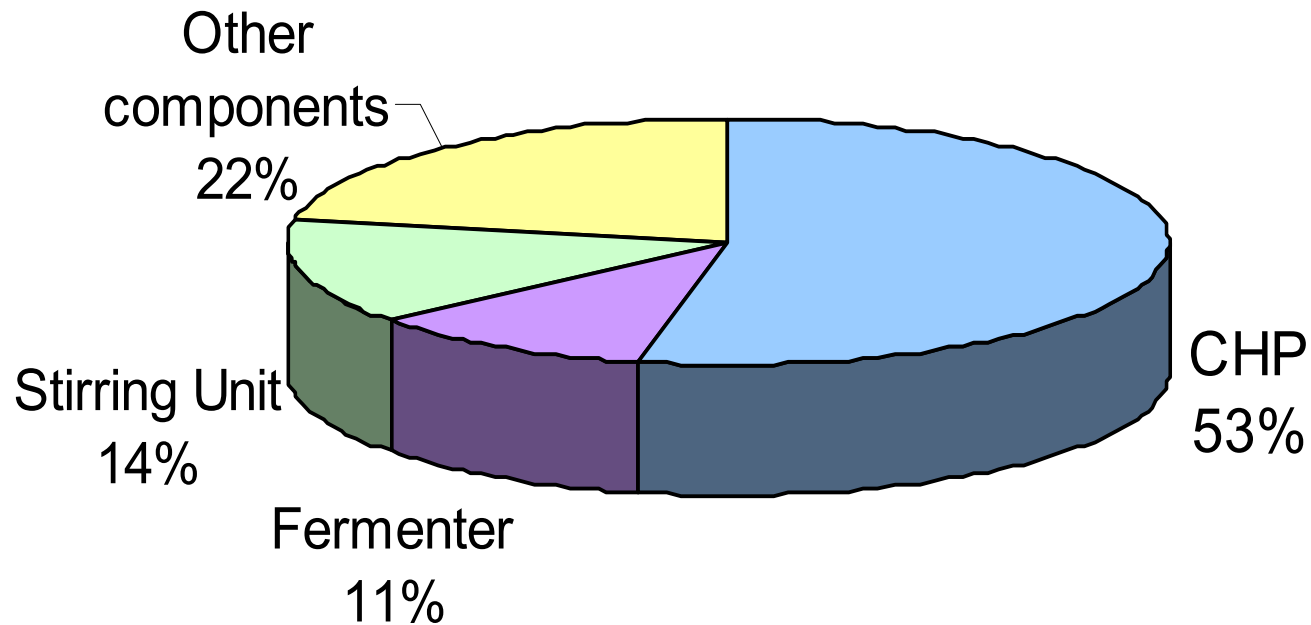

MMC Marsh & McLennan Companies

Engine Breakdowns

- Mostly consequence of poor Biogas Quality



- Fluctuating composition and calorific value of the biogas
- High exposure to aggressive acid substances, especially hydrogen sulfide
- Missing or deficient gas drying / cleaning systems
- Too small dimensioned gas storages
- High strain of particulates in the biogas
- Insufficient quality of oil because of too long oil change intervals
- Deficient control and documentation of the motor performance data, general bad maintenance of the CHP
- Clogging of cooling circuits

Consequences - The Operation Journal



Minimum requirement of the operation journal:

Datum	Uhrzeit	Gaszählerstand	Stromzählerstand	Motorleistung	Kühlwassertemperatur	Schmieröltemperatur	Schmieröldruck	Abgastemperatur	Bemerkungen

⇒ **Measurement at least once a day manual
or
continuous automatic measure and storage**

Consequences - Gas Quality and Control



Recital Clause:

- Desulphurization and drying
- Daily control of the sulfur and methane content
- Online control is advisable
- ⇒ **Avoidance of the most common engine breakdowns**
- Permanent control by employees or automatic systems
- ⇒ **Breakdowns have to be reported immediately to limit damages**

Consequences - Warranty and Maintenance



Recital Clause:

- At least 6 months warranty of the engine producer
- ⇒ **Approved technology can be insured, but no experimental plants**
- Maintenance contract with engine producer or a specialist company
- Maintenance and inspection according to the operation journal of the engine producer
- ⇒ **A professional maintenance stretches the age of the engine and reduces damage risks**

Consequences - Oil Analyses



Recital Clause:

- Oil analysis with at least every second oil change
 - Evaluation of the result by the service firm
 - Result has to be kept in the operating journal
-
- ⇒ **The state of the engine, e.g. wear and tear, and the gas quality can be estimated by the oil analysis**
 - ⇒ **The oil changing intervals can be attuned to the oil quality**

Advantages of an extensive and coherent Risk and Insurance Management



- Only one All Risk Insurance Contract for unexpected happened damages and losses
- Entire Biogas Plant – no disqualification, no difference between buildings or equipment
- Consequential Damage by wear and tear/corrosion
- Amortization/depreciation just for some components of the engine
- Late start of operation after material damage during construction
- Special extended cover for the biology
- Support by independent Engineers and Scientists to achieve acceptance of your claims by the insurer



谢谢各位领导专家



谢谢 Thank you!

- 请多提宝贵意见。

Heinz-Peter Mang

mang@gerbio.org

mang@ieep.net